

# Tanking Instructions

## Butyl

The minimum area to be made waterproof is 1 metre up the height of the wall, and 1 metre into the room from the edge of the wetroom former. The aim is to make the entire existing area surrounding the wetroom former one continuous waterproof material to the drain.

**1** Check that the suitable substrate is sound, free of any contaminants, and remove any loose material. Any gaps should be filled with a flexible tile adhesive. Dilute the primer 1:1, and apply to the area.

.....

**2** Install first the butyl corners, then the butyl tape to all joints between surfaces surrounding the area. Finally, install the 1-metre-wide Butyl Waterproofing membrane, overlapping all the tape/corner/s.

.....

**3** Apply the Butyl sealant to all gaps/joints, and where any pipework passes through the membrane.

.....

This area is now ready to tile.

# Tanking Diagrams All Products

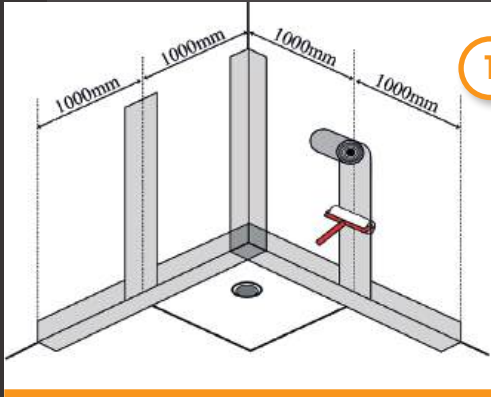

1



2

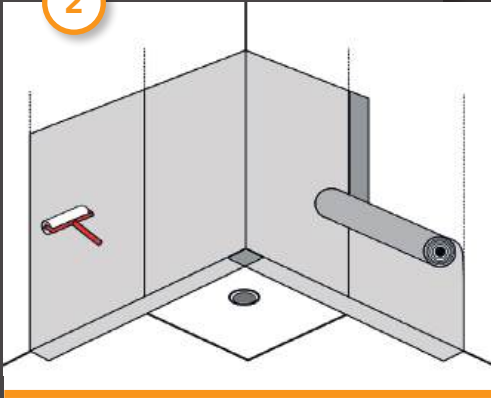

3

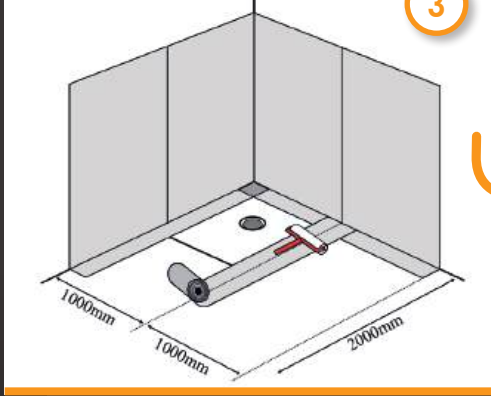

4

